

B. STRUCTURE OF NUCLEI VERY FAR FROM THE VALLEY OF STABILITY

The program to explore the structure and stability of nuclei along the proton dripline continues to be a forefront theme in our nuclear structure research. It has many interesting facets, both for astrophysical processes and for extending our understanding of the structure and stability of nuclei. It provides a natural bridge that connects contemporary research with future projects which exploit radioactive beams. The successful Gammasphere campaign at ATLAS during 1998-2000 led to the acquisition of a vast amount of new data on far from stability nuclei. During the present LBNL Gammasphere cycle, we have been able to complete much of the analysis backlog, resulting in an unusually high level of publication. Plans for a higher sensitivity level of operation of Gammasphere are being developed, with the possibility of spectroscopy even further from stability during the next cycle starting in 2002. The techniques of proton decay spectroscopy also continue to be refined, allowing studies of shorter lived, and more weakly produced species further from stability. In both cases, upgrades to the FMA have increased sensitivity.

The possibility of studying the structure of very neutron-rich nuclei in the future seems very good, including some nuclei close to the predicted r-process nucleosynthesis trajectory. In this domain conventional heavy-ion fusion-evaporation is not useful, due to the curvature of the valley of stability, but by investigating the prompt gamma-ray spectroscopy of fission fragments, and by studying gamma-rays following multi-nucleon transfer reactions, very considerable progress is possible. Many of these studies provide a natural compliment to the data recently obtained from fast-fragmentation facilities. The fast fragmentation allows the identification of low-lying states in these nuclei, which can be developed in many cases with detailed spectroscopy using Gammasphere. Particular progress has been made in the region around ^{132}Sn . In addition to spectroscopic information, the precise determination of the masses of hundreds of very neutron-rich fission fragments now appears possible, using the gas-cooler and CPT.

B.1. Proton-Rich Nuclear Spectroscopy

b.1.1. Low Level Density in Odd-Odd $N = Z$ Nuclei in the $A \sim 70$ Region (C. J. Lister, D. G. Jenkins,^{a,*†} N. S. Kelsall,[‡] D. P. Balamuth,^{*} M. P. Carpenter, [†] T. A. Sienko, [†] S. M. Fischer,[§] R. M. Clark,[¶] P. Fallon,[¶] A. G6rgen,[¶] A. O. Macchiavelli,[¶] E. Svensson,[¶] R. Wadsworth,[‡] W. Reviol, D. G. Sarantites, G. C. Ball,^{**} J. Rikovska Stone,^{††,‡‡} O. Juillet,^{§§} P. Van Isacker,^{§§} A. V. Afanasjev,^{†,¶¶,||} and S. Frauendorf^{¶¶,***})

Studying odd-odd $N = Z$ nuclei above nickel is topical for several reasons. The nuclei lie along the explosive rp-nucleosynthesis path, so their masses, shapes, decays and isomers need to be known for modeling x-ray bursts. The nuclei decay by "super allowed" Fermi β -decays, which, if precisely measured, can allow searches for physics beyond the standard model as long as small structure-dependent corrections can be made. Finally, the nuclei have near-degenerate low-lying configurations with $T = 0$ and $T = 1$ symmetries, so information on both long- and short-range np correlations may be sought. The experiments are technically challenging, as the production cross-sections are always low, and the decay patterns complicated. The key information lies in the low spin

states, but only heavy-ion reactions, either through fragmentation or fusion, can allow us access to these nuclei for spectroscopy. However, in the last few years heroic progress has been made in experiments on copper, gallium, arsenic, bromine, rubidium and yttrium nuclei which span this region. There have also been dozens of theoretical investigations into these matters. We have focused on a detailed study of $^{70}\text{Br}^1$, a nucleus which has a β -decaying high spin isomer, but otherwise no other levels were known. The experiments were aimed at as complete spectroscopy as is possible using current techniques, with the goals of investigating np-interactions and locating the (known) isomer. The experiments were quite successful in both regards.

A compilation of information so far gleaned from all the odd-odd nuclei in the region reveals a striking difference between the $N = Z$ nuclei and their neighbors. Several conclusions can be drawn from the data collected to date:

- (1) The number of states in the first MeV of excitation in the $N = Z$ nuclei is very low. This does not seem to be an experimental artifact. Figure I-8 illustrates the difference between $N = Z$ and $N > Z$ odd-odd nuclei in the region. This observation strongly constrains correlations between the uncoupled neutron and proton.
- (2) There is little evidence for low-lying $J^\pi = 1^+$ states, which would be a fingerprint of very strong $T = 0$ np-pairing correlations.
- (3) The low-lying shapes of the odd-odd nuclei seem to closely follow their neighboring even-even cores.
- (4) The location of analogs to the ground state bands in $(Z - 1, N + 1)$ isobars is difficult, as these states are quite non-yrast, so “mirror symmetry” tests are extremely challenging.
- (5) The known isomers arise from a wide variety of shapes and structure and do not have a single, common cause.

^aPresent address: Oliver Lodge Laboratory, University of Liverpool, UK, ^{*}University of Pennsylvania, [†]Argonne National Laboratory, [‡]University of York, UK., [§]DePaul University, [¶]Lawrence Berkeley National Laboratory, ^{||}Washington University, ^{**}TRIUMF, ^{††}University of Oxford, UK, ^{‡‡}University of Maryland, ^{§§}Grand Accelérateur National d'Ions Lourds, France, ^{¶¶}University of Notre Dame, ^{|||}University of Latvia, ^{***}IKH, Rossendorf Research Centre, Germany
¹D. G. Jenkins *et al.*, Phys. Rev. **C65**, 064307 (2002).

ANL-P-22,765

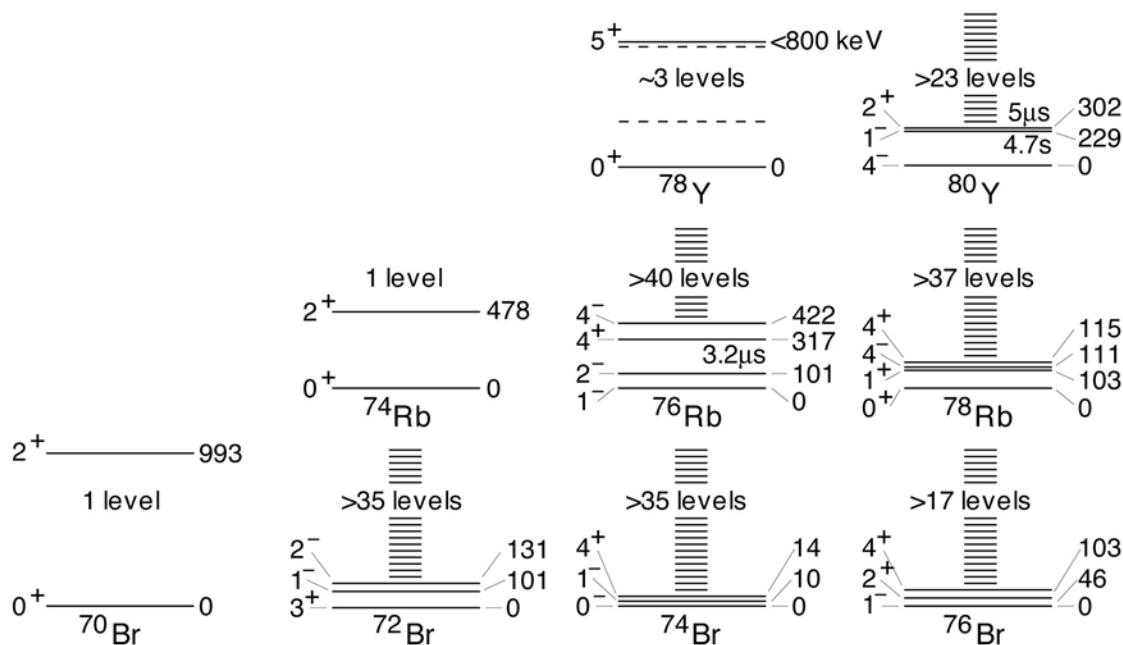

Fig. I-8. A compilation of known low-lying states in odd-odd nuclei in the mass $A \sim 70$ region. It is clear that the $N > Z$ nuclei have many more states than those with $N = Z$. Some of this difference can be attributed to collective rotational bands built on the intrinsic configurations, but even after accounting for this difference, there are still many less intrinsic states in the $N = Z$ nuclei.

b.1.2. Alignment Effects in $^{72,73}\text{Kr}$ (S. M. Fischer,* C. J. Lister, M. P. Carpenter, R. V. F. Janssens, D. Seweryniak, D. P. Balamuth,† N. S. Kelsall,‡ G. C. Ball,§ R. Bauer,¶ J. A. Becker,¶ L. A. Bernstein,¶ R. M. Clark,|| J. Durell,** P. Fallon,|| N. Fotiades,†† S. J. Freeman,** P. E. Garrett,¶ P. A. Hausladen,† D. G. Jenkins,† M. Leddy,** A. O. Macchiavelli,|| J. Ressler,‡‡ D. G. Sarantites,¶¶ D. C. Schmidt, ‡‡‡ J. Schwartz,§§ D. Svelnys, ‡‡‡ C. E. Svensson,|| B. J. Varley,** S. Vincent,|||| R. Wadsworth,‡ A. N. Wilson,‡ A.V. Afanasjev,|||| S. Frauendorf,|||| I. Ragnarsson,***)

Theory predicts that neutron-proton (np) pairing effects are likely to be quite strong for $N = Z$ nuclei, and then diminish rapidly as one moves away from $N = Z$. It has proven to be both an experimental and theoretical challenge to observe and predict evidence for such effects. One possible effect may be a delay in the frequency at which np pairs break and their angular momentum aligns with the angular momentum of the rotating core. This was first suggested by de Angelis *et al.*,¹ in a study of high spin states in the $N = Z$ nucleus ^{72}Kr . We have recently extended this work on ^{72}Kr , and made additional studies of the $N = Z$ nuclei ^{76}Sr and ^{80}Zr .²

High spin states in ^{72}Kr were populated in the $^{40}\text{Ca}(^{40}\text{Ca},2\alpha)$ reaction at 160 MeV. Data were collected at the ATLAS facility with the Gammasphere and Microball detector arrays. The level scheme for ^{72}Kr was deduced by analyzing 2α -gated $\gamma\gamma$ coincidences and carefully subtracting backgrounds due to feedthrough from the $2\alpha p$ and $2\alpha 2p$ reaction channels. Particle-gated γ -ray angular distributions were used to determine the multipolarity of the transitions. The ground state band was extended to $J^\pi = (26^+)$. Figure I-9 shows the kinematic moments of inertia, $J^{(1)}$, versus frequency for ^{72}Kr (diamonds), ^{74}Kr (dashed) and ^{76}Kr (dotted). The data for $^{74,76}\text{Kr}$ show the sharp simultaneous alignment of neutron and proton pairs at similar frequencies of $\hbar\omega \sim 0.65$ MeV, while the data for ^{72}Kr indicate a delayed, gradual alignment as a function of frequency. This behavior is very different from that of the other $N = Z$ nuclei ^{76}Sr ² and ^{88}Ru ,³ where a much more modest delay in the alignment is observed.

We have performed two studies of ^{73}Kr ⁴ to determine whether a similar dramatic delay occurs for the neighboring odd-A isotope. In the first study, ^{73}Kr was created in the same $^{40}\text{Ca} + ^{40}\text{Ca}$ study that produced ^{72}Kr , but this time utilizing the $\alpha 2pn$ channel and an array of 20 liquid scintillator counters from the Universities of Manchester and Pennsylvania. The second study was also performed at ATLAS, and used the $^{40}\text{Ca}(^{36}\text{Ar},2pn)$ reaction at 145 MeV with the Gammasphere and Microball arrays plus a complement of 30 neutron detectors. The negative parity bands 1 and 2 of ^{73}Kr have been extended to spins $(63/2^-)$ and $(61/2^-)$, and the positive parity band 3 to spin $(57/2^+)$. In addition, the signature partner of the positive parity band was observed for the first time to $J^\pi = (31/2^+)$. Figure I-10 shows the Routhians, e' , as a function of the rotational frequency $\hbar\omega$ for bands 1-3. The solid and dashed curves show the results of Total Routhian Surface (TRS) calculations⁴ for two possible configurations. The observed alignment frequencies are systematically delayed relative to the theoretical predictions, although with a much smaller delay than in ^{72}Kr . Similar calculations are in excellent agreement with the experimental data for ^{75}Kr .

The alignment delay in ^{73}Kr is consistent with what might be expected for an odd-A nucleus based on the delays observed for ^{76}Sr and ^{88}Ru . However, whether these delays are indeed a consequence of np pairing remains in question. We know that alignment frequencies depend very sensitively on the shape of the nucleus, and that the nuclear shape can change with rotational frequency, as evident from a recent study of ^{74}Kr .⁵ Because of this, experimental measurements

*Argonne National Laboratory and DePaul University, †University of Pennsylvania, ‡University of York, United Kingdom, §TRIUMF Laboratory, Canada, ¶Lawrence Livermore National Laboratory, ||Lawrence Berkeley National Laboratory, **University of Manchester, United Kingdom, ††Rutgers University, ‡‡University of Maryland, §§Yale University, ¶¶Washington University, ||||University of Notre Dame, ***Lund Institute of Technology, Sweden, †††The Royal Institute of Technology, Sweden, ‡‡‡DePaul University

¹G. de Angelis, *et al.*, Phys. Lett. **B415**, 217 (1997).

²S. M. Fischer, *et al.*, Phys. Rev. Lett. **87**, 132501 (2001).

³N. Marginean, *et al.*, Phys. Rev. C **63**, 031303 (2001).

⁴N. Kelsall, *et al.*, Phys. Rev. C **65**, 044331 (2002).

⁵A. Algora, *et al.*, Phys. Rev. C **61**, 031303 (2000).

of the quadrupole deformation as a function of frequency are essential to our progress in understanding these nuclei, and should help to disentangle the shape and pairing degrees of freedom. The behavior of ^{72}Kr at high spin is clearly unusual and strikingly different from its odd-A neighbor, ^{73}Kr . We note that

an irregular sequence of γ rays was observed to feed into the main cascade above $J = 14$. We are currently working to understand this structure, its relationship to the main cascade which is clearly favored at very high spin, and its relationship to a similar positive parity band in ^{74}Kr .

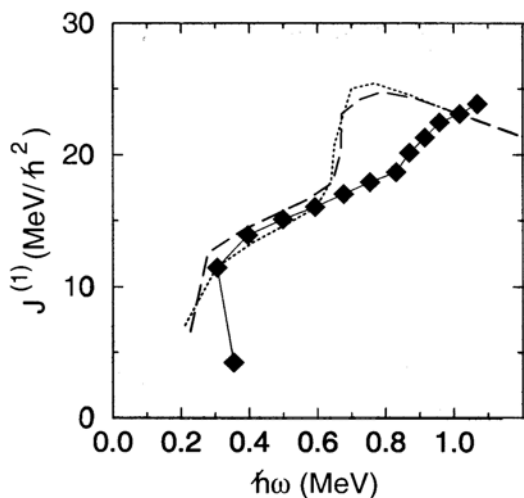

Fig. I-9. Kinematic moment of inertia versus rotational frequency for ^{72}Kr (diamonds), ^{74}Kr (dashed), and ^{76}Kr (dotted).

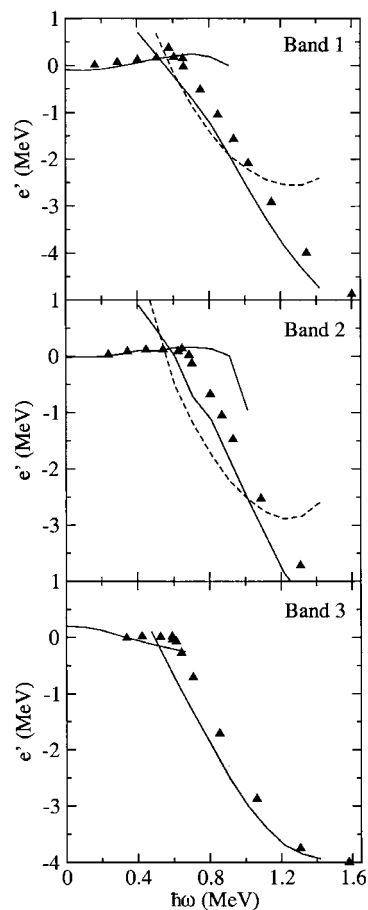

Fig. I-10. Routhians as a function of rotational frequency for the negative parity bands 1 and 2, and positive parity band 3 of ^{73}Kr . The dashed and full curves show the results of TRS calculations for two possible configurations.

b.1.3. New Results in Proton Radioactivity (C. N. Davids, D. Seweryniak, A. Heinz, P. J. Woods,* J. J. Ressler,† J. Shergur,† H. Mahmud,* P. Munro,* A. Robinson,* T. Davinson,* A. A. Sonzogni,‡ and W. B. Walters†)

The new proton emitter ^{135}Tb has been observed. It was produced with an estimated cross section of 2 nb via the $^{92}\text{Mo}(^{50}\text{Cr}, p6n)$ reaction, the first time that this extremely weak reaction channel has been used in proton radioactivity studies. The energy spectrum is shown in Fig. I-11. We observe a single proton peak around 1.18 MeV, with a half-life of <1 ms. This proton emitter is expected to be highly deformed. Data analysis is continuing.

A search for the heavy proton emitter ^{191}At ($Z = 85$) proved to be inconclusive. We used the $^{144}\text{Sm}(^{50}\text{Cr}, p2n)$ fusion-evaporation channel, but experienced

problems with target deterioration during bombardment, even though the targets were rotated and the beam was wobbled in the vertical plane to reduce heat deposition. We did observe $A = 191$ recoils, from ^{191}Po , and believe that the experiment to observe ^{191}At is still feasible under improved target conditions.

An experiment to search for the deformed proton emitter ^{125}Pm has been approved by the PAC. This experiment will be performed after installation and testing of the new split anode for the FMA is completed.

*University of Edinburgh, United Kingdom, †University of Maryland, ‡National Nuclear Data Center

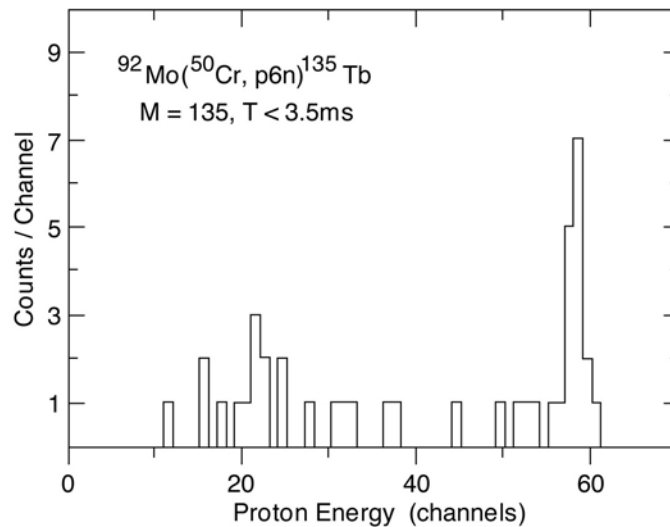

Fig. I-11. Energy spectrum of decay events correlated with $A=135$ and within 3.5 ms of implantation.

b.1.4. Population of the 168 keV First Excited State in ^{103}Sn in the Alpha Decay of ^{107}Te (D. Seweryniak, C. N. Davids, W. B. Walters,* A. Woehr,* M. Lipoglavsek,† J. Shergur,* and J. J. Ressler*)

There has been considerable interest in the structure of the light odd-mass Sn nuclides as the states observed there reflect the interactions between valence $d_{5/2}$ and $g_{7/2}$ neutrons in small numbers. Recently, Fahlander *et al.*¹ reported a new study of the excited states in ^{103}Sn that included a 168 keV energy for the $g_{7/2}$ first excited state. In previous extrapolations from the known structures in the heavier Sn nuclides, such as the one published by Sandulescu, Blomqvist and Liotta,² a smooth upward movement was expected for these $g_{7/2}$ states. In particular, as the $7/2^+$ level is found at 200 keV in ^{105}Sn , an energy as high as 350 keV was expected for this same state in ^{103}Sn . Therefore, the observation of the state at 168 keV was a surprise.

However, the low energy opened up the possibility of populating this state via alpha decay from 3 ms ^{107}Te . The Q-value for alpha decay is about 4.00 MeV, as established by the observation of an alpha energy of 3862(10) keV.³ Recoils with mass 107 from the $^{58}\text{Ni}(^{54}\text{Fe},2p3n)$ reaction were isolated with the Fragment Mass Analyzer and implanted into a double-

sided Si strip detector (DSSD). A gamma-ray detector was mounted behind the DSSD to permit alpha-gamma coincidence measurement. The resulting α spectrum is shown in Fig. I-12 where the small peak about 160 keV below the main peak can be readily seen. The area of this peak corresponds to 0.47(9)% of the area of the peak at 3860 keV. In the α - γ coincidence matrix (see Fig. I-13), there were three events where γ rays at 168 keV were in coincidence with the weak α line, and no γ -ray events in coincidence with the main α branch at 3860 keV. The unhindered $l = 2$ transition rate to the 168 keV level was calculated to be 6% relative to the main branch, yielding a hindrance of about 12. As this is the first well established “fine structure” in this mass region, comparisons with other hindrance factor are not possible.

In another short experiment the $^{58}\text{Ni}(^{58}\text{Ni},2p3n)$ reaction was used to study ^{111}Xe α -decay fine structure. The evidence for α - γ coincidences following the decay of ^{111}Xe is being analyzed.

*University of Maryland, †J. Stefan Institute, Ljubljana, Slovenia

¹C. Fahlander *et al.*, Phys. Rev. C 63, 021307R (2001).

²N. Sandulescu, J. Blomqvist, and R. J. Liotta, Nucl. Phys. A582, 257(1995).

³P. Heine *et al.*, Z. Phys. A34, 225(1991).

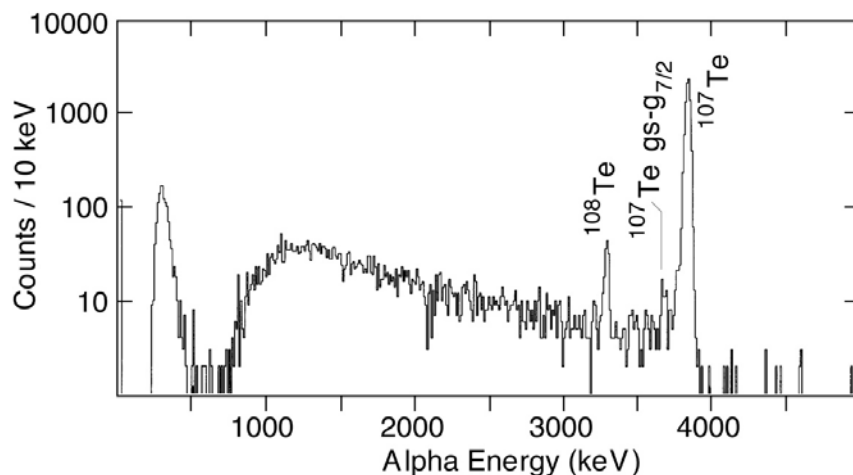

Fig. I-12. A portion of the α -decay spectrum measured using the $^{58}\text{Ni}(^{54}\text{Fe},2p3n)$ reaction.

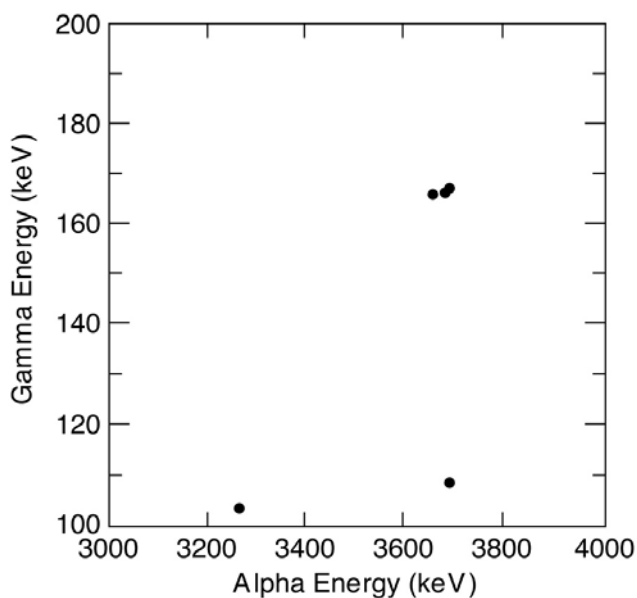

Fig. I-13. A portion of the α - γ matrix, clearly showing the correlation between the α -decay to the 168-keV state and its subsequent γ -decay.

b.1.5. New Method to Study Sub- μ s Proton and α Emitters (D. Seweryniak, A. Heinz, C. N. Davids, G. Mukherjee, J. J. Ressler,* J. Shergur,* and A. Woehr*)

The majority of methods for studying proton and α activities are based on the use of recoil mass separators. The time-of-flight of recoiling nuclei through a separator limits the observable half lives to 0.5 μ s and longer. The most exotic proton emitters have even shorter half lives.

A technique has been being developed to study proton and α activities down to half lives of about 1 ns. The experimental setup is shown in Fig. I-14. Products of heavy-ion fusion evaporation reactions are slowed

down in a Au degrader foil and are implanted on a surface of a thin catcher foil. Beam particles which do not undergo reaction in the target pass through the holes in the degrader and the catcher. The decay protons and α particles emitted by the implants are caught in 3 Si Δ E-E telescopes placed at backward angles with respect to the catcher.

This technique was tested using the $^{58}\text{Ni}(^{58}\text{Ni},p2n)^{113}\text{Cs}$ reaction. ^{113}Cs is a proton emitter which decays with the half life of about 15 μ s. In order to reduce

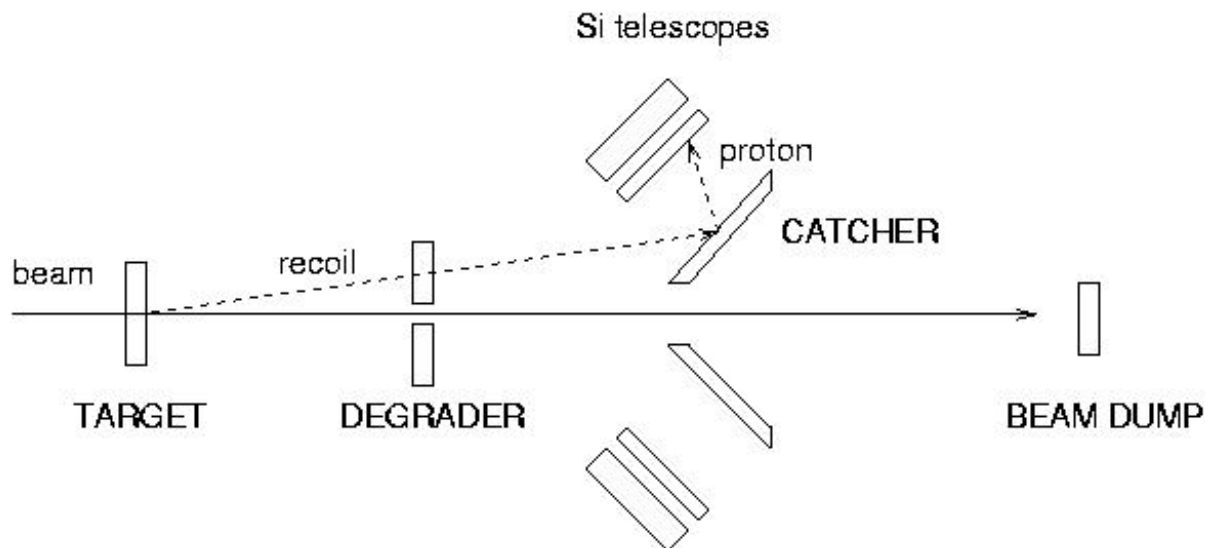

Fig. I-14. The experimental setup for studies of fast proton and α emitters.

background the target was irradiated for about 30 μ s and the beam was turned off for about 60 μ s to measure radioactivity. About 600 protons were observed in about 16 hours during the test. The measured proton spectrum is shown in Fig. I-15. The expected delayed proton peak near 900 keV is clear. Considerable effort is now being directed at understanding the underlying background which determines the sensitivity of this method at present.

In another experiment the $^{32}\text{S}(^{40}\text{Ca},p2n)$ reaction was used to produce the predicted proton emitter ^{69}Br . The upper limit of about 100 ns for its half life has been obtained from in-flight fragmentation experiments at GANIL and MSU. Due to much shorter half life in comparison to ^{113}Cs 3 beam pulses out of 4 were swept away. The background reduction achieved allowed us to study proton emitters produced with a cross section as low as 10 μ b, provided the lifetime were long enough for the residues to reach the catcher. Data analysis is in progress.

*University of Maryland

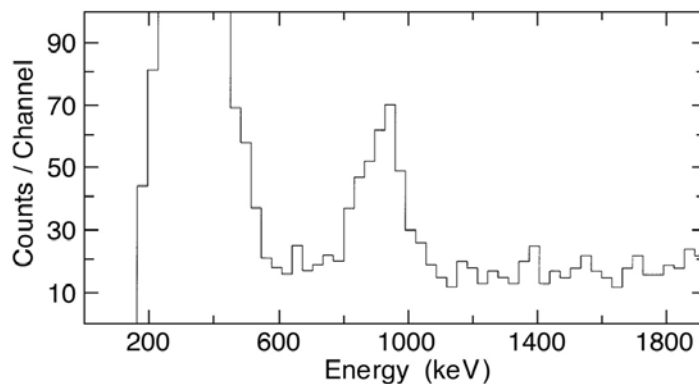

Fig. I-15. ^{113}Cs Proton spectrum measured using the $^{58}\text{Ni}(^{58}\text{Ni},p2n)$ reaction.

b.1.6. Identification of Excited States in ^{140}Dy (M. P. Carpenter, C. N. Davids, R. V. F. Janssens, C. J. Lister, D. Seweryniak, I. Ahmad, A. Heinz, T. L. Khoo, E. F. Moore, F. G. Kondev,* D. M. Cullen,† A. M. Fletcher,† S. J. Freeman,† L. K. Pattison,† J. F. Smith,† A. M. Bruce,‡ K. Abu Saleem,§ G. Mukherjee,¶ C. Wheldon,|| and A. Woehr**)

Recently, a new region of deformed proton emitters has been established ranging from La to Tm. The first cases found were in ^{131}Eu and ^{141}Ho .¹ Initially, the deformation and single-particle parentage of the proton-emitting states were deduced from calculations employing the multiparticle theory of Bugarov and Kadmsky.² In the case of ^{141}Ho , the deformation of the proton emitting states were confirmed by in-beam γ -ray spectroscopy utilizing the Recoil Decay Tagging (RDT) technique which established rotational bands on top of the these states.³ While the deformation of the ^{141}Ho rotational bands deduced from the in-beam work is consistent with those inferred from the proton decay measurements, critical information about the ^{140}Dy daughter nucleus was still missing. One of the important assumptions in the calculations of the decay rates from deformed proton emitters is that the parent and daughter have the same deformation. Proton emission to the 2^+ level in ^{140}Dy has not been observed, however, an upper limit for the branching ratio between the 2^+ and 0^+ feedings into ^{140}Dy has been placed at 1% for decays from the assigned $7/2^-$ ^{141}Ho , ground state.³ Due to the fact that ^{140}Dy decays by β emission, in-beam γ spectroscopy using the RDT technique is not possible.

Recently, Cullen *et al.*⁴ suggested that the yrast band of ^{140}Dy could be identified at least up to the 8^+ level by

measuring γ rays emitted following the decay of a predicted $K = 8^-$ isomer. Studies to identify this isomer in ^{140}Dy and its subsequent γ decay were performed recently at the ATLAS facility by looking for delayed γ rays after implantation of mass selected recoils at the focal plane of the Fragment Mass Analyzer. From an analysis of the data, the 8^- isomer in ^{140}Dy was established at 2.16 MeV, and its subsequent decay by γ emission was followed to the ground state. The half-life of the isomer was measured to be $7.3(15) \mu\text{s}$, and the excitation energy of the 2^+ state is 202 keV. Figure I-16 shows both the time spectrum associated with the decay of the isomer and the proposed level structure deduced from the isomer's decay. Using the Grodzins formula, the deformation of the ground state in ^{140}Dy is deduced to be $\beta_2 = 0.24(3)$ which agrees well with the value of $0.25(3)$ deduced for the rotational bands in ^{141}Ho . The new information obtained here supports the role of deformation in proton emission and the previous assignments of single-particle configurations to the two proton emitting states in ^{141}Ho . In addition, the reduced hindrance factor measured for the isomer is consistent with the trend observed for 8^- isomers in the lighter even-even $N = 74$ isotones.

A paper reporting the results of this work was recently published in Physics Letters B.⁵

*Technology Division, Argonne National Laboratory, †University of Manchester, United Kingdom, ‡University of Brighton, United Kingdom, §Illinois Institute of Technology, ¶University of Massachusetts-Lowell, ||University of Surrey, Guildford, United Kingdom, **University of Maryland

¹C. N. Davids *et al.*, Phys. Rev. Lett. **80**, 1849 (1998).

²V. P. Bugrov and S. G. Kadmsky, Sov. J. Nucl. Phys. **49**, 967 (1989).

³D. Seweryniak *et al.*, Phys. Rev. Lett. **86**, 1458 (2001).

⁴D. M. Cullen *et al.*, Nucl. Phys. **A682**, 264c (2001).

⁵D. M. Cullen *et al.*, Phys. Lett. **B529**, 45 (2002).

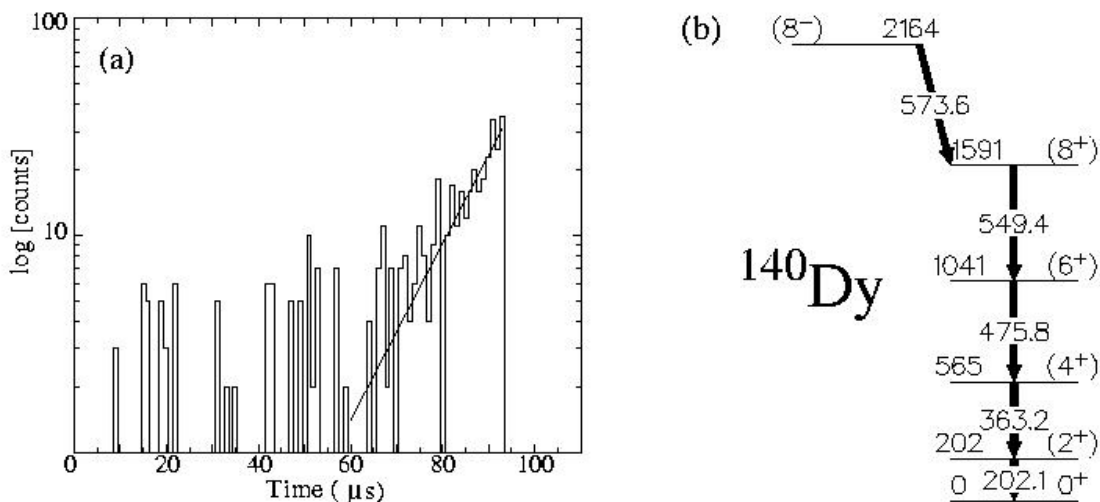

Fig. I-16. (a) Time delay between the implant of a residue and the detection in prompt coincidence of any two of the five γ transitions associated with the decay of the isomer. The solid line represents a fit to the data which yields a half-life of 7.3 μ sec. (b) Proposed level sequence following the decay of the 8⁻ isomer in ^{140}Dy .

b.1.7. Shape Coexistence Far from Stability (M. P. Carpenter, F. G. Kondev, R. V. F. Janssens, I. Ahmad, J. Caggiano, C. N. Davids, A. Heinz, T. L. Khoo, T. Lauritsen, C. J. Lister, G. L. Poli, P. Reiter, D. Seweryniak, A. A. Sonzogni, I. Wiedenhöver, K. Abu Saleem,* H. Amro,† J. A. Cizewski,‡ M. Danchev,§ D. J. Hartley,§ B. Herskind,¶ W. C. Ma,† J. Ressler,|| W. Reviol,** L. L. Riedinger,§ D. G. Sarantites,** S. Siem,†† M. B. Smith,‡ and P. G. Varnette†)

Above $N = 82$, the proton dripline follows closely the outer edges of the well deformed rare-earth region, and the ground states of nuclei which make up the dripline here are expected to have spherical or modestly deformed prolate shapes. Our recent experimental studies have concentrated in the upper portion of this region, namely the study of excited states in Os ($Z = 76$) through Pb ($Z = 82$) isotopes located in the vicinity of the proton dripline. One of our principle motivations has been to characterize the evolution of shape from the well studied deformed region to the near spherical ground states which constitute the dripline proton emitters.

In-beam γ -ray studies of such heavy systems far from stability are hampered by the large fission cross sections associated with the heavy-ion fusion reactions which are used to produce these proton-rich nuclides. However, the use of recoil separators allows one to easily distinguish fusion-evaporation residues from fission products. In addition, all nuclides in this region which lie at the dripline or beyond, decay via charge particle radioactivity. As a result, the recoil decay tagging (RDT) technique can be utilized allowing for in-beam γ -ray studies of nuclides produced with sub- μ b

cross-sections. By coupling the Fragment Mass Analyzer (FMA) with Gammasphere, the high-spin structure of a number of nuclides in this Os-Pb region have been investigated. In addition, complimentary decay studies of these same nuclides has allowed, in several instances, spin/parity and excitation energy assignments for all observed states.

Nearly all isotopes studied in this region exhibit evidence of shape-coexistence i.e. states at low-excitation energy built on two distinct shapes. For two isotopes, $^{175}\text{Au}^1$ and $^{179}\text{Hg}^2$, three shapes have been identified; moderately-deformed oblate, well-deformed prolate and near-spherical. Figure I-17 shows the new level schemes deduced for $^{173,175,177}\text{Au}$. Besides the three shapes identified in ^{175}Au , the new data on these three Au isotopes show a progression from a domination of deformed structures in ^{177}Au to no evidence of collectivity in ^{173}Au . Figure I-18 shows the level structure deduced for ^{179}Hg . In the heavier odd-A Hg isotopes, the ground state spin/parity is $1/2^-$ and associated with a deformed configuration. For ^{179}Hg , the ground state is established to be $7/2^-$ and is associated with a near-spherical shape.

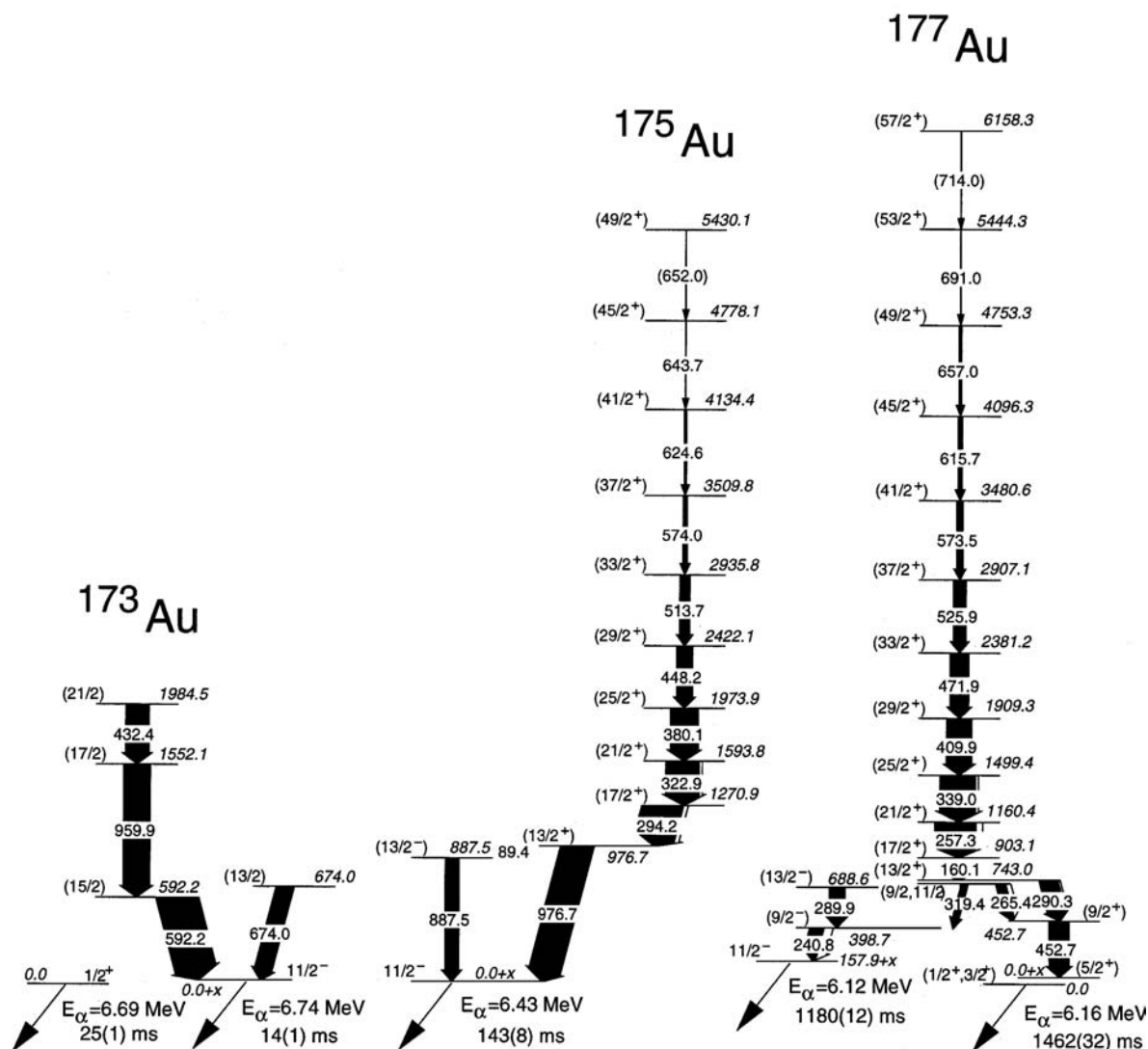

Fig. I-17. Level schemes for $^{173,175,177}\text{Au}$ deduced from γ -ray coincidence data measured with Gammasphere. High-spin states in these nuclei were populated via the $p2n$ evaporation channel from reactions using an ^{84}Sr beam on isotopically enriched targets of ^{92}Mo , ^{94}Mo and ^{96}Mo . The beam was supplied by the ATLAS accelerator at Argonne National Laboratory.

Three rotational bands are evident in the level scheme and have a deduced prolate deformation of $\beta_2 \sim 0.2$.

The oblate shape is associated with the $13/2^+$ isomer into which rotational band 3 decays into.

*Argonne National Laboratory and Illinois Institute of Technology, †Mississippi State University, ‡Rutgers University, §University of Tennessee, ¶Niels Bohr Institute, Copenhagen, Denmark, ||Argonne National Laboratory and University of Maryland, **Washington University, ††Argonne National Laboratory and University of Oslo, Norway

¹F. G. Kondev *et al.*, Phys. Lett. B **512**, 268 (2001).

²F. G. Kondev *et al.*, Phys. Lett. B **528**, 221 (2002)

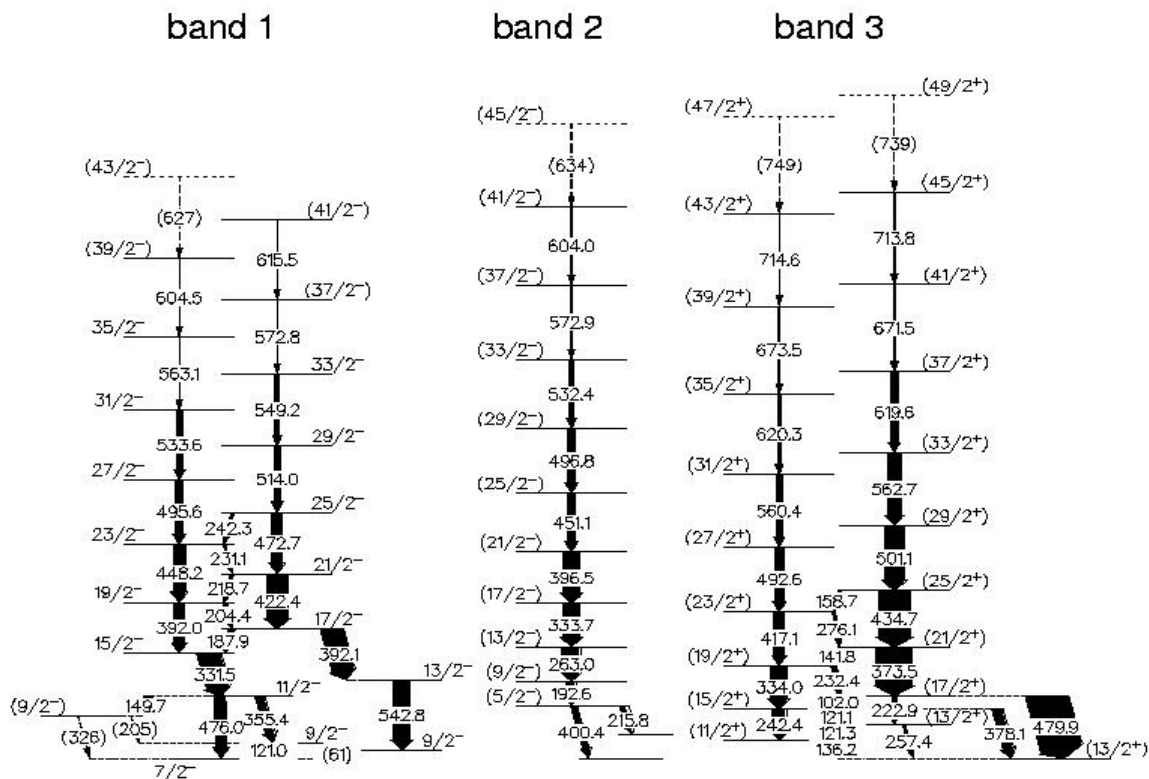

Fig. I-18. Level scheme for ^{179}Hg deduced from γ -ray coincidence data measured with Gammasphere. High-spin states in ^{179}Hg were populated in the $^{90}\text{Zr}(^{90}\text{Zr},n)$ reaction. The beam was supplied by the ATLAS accelerator at Argonne National Laboratory.

B.2. Neutron-Rich Nuclear Spectroscopy

b.2.1. A New Technique for Measuring g-Factor of Excited States in Fission

Fragments Using Gammasphere (I. Ahmad, J. P. Greene, C. J. Lister, R. V. F. Janssens, T. Lauritsen, D. Seweryniak, M. P. Carpenter, F. Kondev, D. Patel,* A. G. Smith,* G. S. Simpson,* R. M. Wall,* J. F. Smith,* O. J. Onakanmi,* B. J. P. Gall,† O. Dorveaux,‡ and B. Roux†)

A new technique has been developed to analyze multifold coincidence data on fission fragments and determine g factors. The g-factors determine the magnetic moments of states and are very sensitive to the underlying single-particle configurations. For neutron-rich nuclei, the successful measurement of g-factors following fission will provide a unique window on neutron-rich nuclear structure. The experiment was performed with the Gammasphere while at Argonne using a 100 μCi ^{252}Cf source. Special care was taken in the preparation of the source so that the fission fragments stop in iron reducing Doppler broadening of the gamma-ray peaks. The source was prepared by electroplating ^{252}Cf on a 15-mg/cm² iron foil and then placing another 15-mg/cm² Fe foil, on which In was evaporated, and pressing the sandwich

under a roller. The source was placed at the center of Gammasphere. A pair of small permanent magnets applying a field of 0.2 T were placed on either side of the source. The direction of the field was reversed every few hours by rotating the magnet assembly through 180 degree. The values of g factors for several nuclei were determined from the analysis of time-integral, perturbed angular correlation functions. The g-factor of the $I^\pi = 2^+$ state in ^{104}Mo was determined from the present data to be +0.248(22). This new measurement shows a factor of 5 improvements in the precision over the value attained in more conventional experiments. The theory behind this new technique and its application to our present data has just been published.¹

*University of Manchester, United Kingdom, †IREs, Strasbourg, France

¹D. Patel et al., J. Phys. G: Nucl. Part. Phys. **28**, 649 (2002).

b.2.2. Medium-Spin Structure of $^{96,97}\text{Sr}$ and $^{98,99}\text{Zr}$ Nuclei and the Onset of Deformation in the $A \sim 100$ Region (I. Ahmad, W. Urban,* J. L. Durell,† A. G. Smith,† W. R. Phillips,† M. A. Jones,† B. J. Varley,† T. Rzaca-Urban,* L. R. Morss,§ M. Bentaleb,‡ and N. Schulz‡)

The structures of $N = 58,59$ nuclei $^{96,97}\text{Sr}$ and $^{98,99}\text{Zr}$ produced in the spontaneous fission of ^{248}Cm were studied with the Eurogam2 array. Level schemes were constructed from the coincidence relationship of gamma rays which are obtained from the detailed analysis of the $\gamma\gamma\gamma$ cubes. Spins and parities of levels were deduced from the angular correlations and directional-polarization correlations. Regular rotational bands were found in ^{97}Sr and ^{99}Sr , firmly establishing shape coexistence in both nuclei. Rotational bands were identified on 0_3^+ states in the $N = 58$ isotones ^{96}Sr and ^{98}Zr . Several negative-parity single-particle

excitations were observed in these nuclei which suggest the important role of $h_{11/2}$ shell in creating deformation. Quadrupole moments were determined for rotational bands in the $N = 58,59,60,62$ and 64 Sr and Zr nuclei. Deformation parameters, which increase gradually from $\beta_2 \sim 0.1$ at $N = 56$, through $\beta_2 \sim 0.2$ at $N = 58$ to $\beta_2 \sim 0.4$ at $N = 64$, suggest that in Sr and Zr isotopes the shape change occurs gradually between $N = 56$ and $N = 62$, and is most likely due to occupancy of three or more deformation driving orbitals of $h_{11/2}$ parentage. These results have been published.¹

*Warsaw University, Poland, †University of Manchester, United Kingdom, ‡IREs, Strasbourg, France, §Chemistry Division, ANL

¹W. Urban et al., Nucl. Phys. **A689**, 605 (2001).

b.2.3. Selective Laser Ionization of $N \geq 82$ Isotopes: Use of the Two Step Target

Technique (A. Woehr,* I. Dillmann,‡ U. Köster,§ V. N. Fedoseyev,¶ M. Hannawald,‡ B. Pfeiffer,‡ D. Fedorov,¶ J. Shergur,† L. Weissmann,‡ W. B. Walters,† and K.-L. Kratz‡)

The region around the neutron-rich, double-magic isotope ^{132}Sn has been the subject of intensive experimental investigations in recent years. One reason for this interest is the evolution of the single-particle structures over nearly 40 mass units between nuclides with $N/Z \cong 1.0$, near ^{100}Sn , and isotopes with $N/Z \geq 1.6$, near ^{132}Sn . Such measurements provide an opportunity to develop a unique approach to nuclear structure with predictive power towards nuclei at the particle drip-lines which are not currently accessible for experimental studies. In recent years, we have performed a number of beta-decay experiments of neutron-rich ($N \geq 82$) Ag, Cd, In and Sn isotopes. These studies have been performed at the CERN/ISOLDE facility using resonant laser ionization techniques prior to mass separation. Subsequently, beta-delayed neutron measurements to determine the half-live and beta-gamma spectroscopy to obtain nuclear structure properties have been used. In this report, we present the first results of a study of the decay of $^{132-135}\text{In}$ isotopes.

Neutron-rich medium mass nuclei are normally produced at ISOLDE by high-energy (1 or 1.4 GeV) proton induced fission of ^{238}U . Unfortunately, with this production mechanism neutron-deficient isobars are also formed in spallation and high-energy fission. The situation is particularly complicated in the mass region near $A \cong 80$ which is dominated by very high

backgrounds resulting from surface-ionized (therefore difficult to suppress) proton-rich isobars of rubidium and caesium, respectively. Fission induced by low to medium energy neutrons, however, does not create this problem. Such neutrons can be produced efficiently by heavy target materials, e.g. tantalum or tungsten. The use of a “mini-spallation-source” surrounded by a concentric ISOL fission target was proposed by Nolen *et al.*¹ While the realization of a concentric target requires sophisticated engineering, it is relatively simple to build a reduced version, by just installing a high-Z rod close to a standard ISOLDE fission target. In this experiment, a 10 mm diameter tantalum rod of 150 mm length was mounted parallel to the ^{238}U target at a distance of 21 mm axis to axis.² In this configuration, only part of the neutron flux produced in the “mini-spallation source” impinges on the ISOL target, but the primary beam and most of the secondary particles are located in a forward cone. In this experiment, a standard ISOLDE UC_x/graphite target³ with 50 g/cm² ^{238}U and about 10 g/cm² carbon was used. The target was kept at 2423 K and the niobium ionizer was kept at 2123 K. Pulses of 1.4 GeV Protons (5.3 μC each) hit the tantalum converter every 2.4 s. The Resonant Laser Ion Source (RILIS) was tuned for the ionization of indium. Details about the laser ionization scheme and the experimental setup can be seen in Ref. 2. The measured yields are shown in Table I.

Table I: Yields and half-lives of heavy indium isotopes from a 50 g/cm² UC_x/graphite target with the RILIS tuned for indium ionization. The yield Y is given in ions per μC of primary proton beam³ hitting the tantalum “converter” rod. Furthermore, the table contains the experimentally obtained β -decay half-lives ($T_{1/2}$) for $^{132-135}\text{In}$ from this work. For further discussion, see Ref. 2.

Isotope	^{130}In	^{132}In	^{133}In	^{134}In	^{135}In
Y [μC^{-1}]	$> 3.5 \cdot 10^5$	8000	900	≈ 95	≈ 2.4
$T_{1/2}$ [ms]		206(6)	165(3)	141(5)	92(10)

*Argonne National Laboratory and the University of Maryland, †University of Maryland, ‡Universität Mainz, Germany, §CERN, Geneva, Switzerland, ¶Petersburg Nuclear Physics Institute, Gatchina, Russia

¹J.A. Nolen *et al.*, AIP Conference Proceedings **473**, 477 (1998).

²I. Dillmann *et al.*, Europ. Phys. J. **A13**, in press.

³J. Lettry *et al.*, Nucl. Instrum. Methods **B126**, 130 (1977)

b.2.4. Magic Nucleus ^{132}Sn and its Odd-Neutron-Hole Neighbor ^{131}Sn (I. Ahmad, D. Seweryniak, I. Wiedenhöver, M. P. Carpenter, R. V. F. Janssens, T. L. Khoo, T. Lauritsen, C. J. Lister, P. Reiter, P. Bhattacharyya,* P. J. Daly,* C. T. Zhang,* Z. W. Grabowski,* B. Fornal,† R. Broda,† and J. Blomqvist‡)

In the exploration of nuclear structure in regions of nuclide chart far from N/Z stability valley, spectroscopic results for such magic nuclei as ^{48}Ni , ^{78}Ni , ^{100}Sn and ^{132}Sn (and their few valence particle neighbors) provide valuable benchmarks. The neutron-rich doubly closed shell nucleus ^{132}Sn has no excited state below 4 MeV and is thus marked as the most magic of all heavy nuclei. The spectroscopy of these nuclei is well worth studying since it should be a prime source of information about nucleon-nucleon residual interactions in an important sector of the nuclear chart.

The knowledge of the structure of ^{132}Sn and its neighbors comes from β -decay studies of fission products and prompt coincidence spectroscopy of fission products with large gamma-ray array. Our first results on the structure of these nuclei came from analysis of data on the fission products of ^{248}Cm measured with the Eurogam2 array. More recently we

performed an experiment with Gammasphere while it was located at Argonne where more rigorous timing conditions were imposed. A ^{248}Cm source was fabricated. A total of 1.8×10^9 fourfold and higher fold coincidence events were collected. The data was sorted offline into various cubes, both prompt and delayed, covering gamma-ray energies up to 5 MeV.

The analysis of the data determined new levels in ^{132}Sn and ^{131}Sn . In the case of ^{132}Sn , our data confirm all levels below 5 MeV reported in ref. 1. Only one new level, 9^+ member of the $\nu f_{7/2} h_{11/2}^{-1}$ multiplet was observed. In ^{131}Sn , several new levels were identified. Figure I-19 shows the level scheme of ^{132}Sn and ^{131}Sn . Interpretation of the observed states in ^{131}Sn and the comparison of the experimental energies with theoretical values are displayed in Fig. I-20. More details can be found in our publication.²

*Purdue University, †IFJ Krakow, Poland, ‡Royal Institute of Technology, Stockholm, Sweden

¹Fogelberg *et al.*, Phys. Scr. **T56**, 79 (1995).

²P. Bhattacharyya *et al.*, Phys. Rev. Lett. **87**, 062502 (2001).

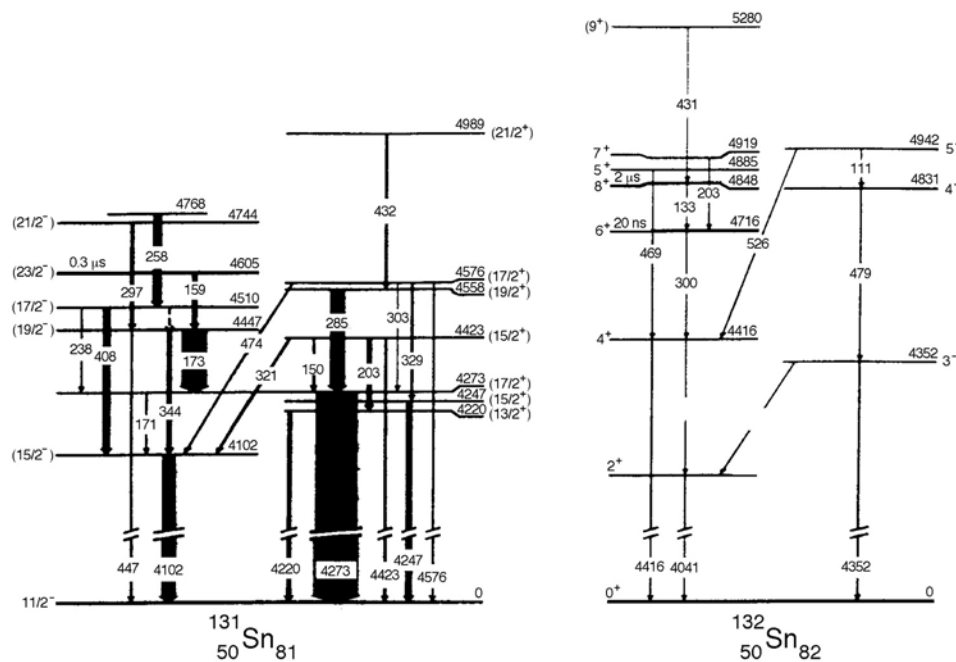

Fig. I-19. Level schemes of ^{131}Sn and ^{132}Sn deduced from analysis of coincidence gamma ray spectra measured with Gammasphere and a 5 mg ^{248}Cm source.

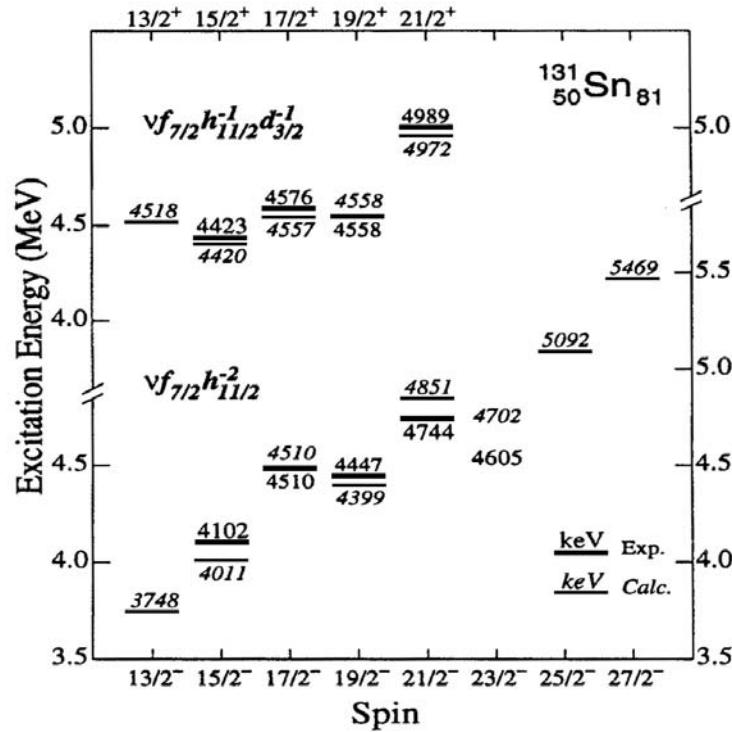

Fig. I-20. Comparison of observed level energies in ^{131}Sn with those calculated by shell model using empirical nucleon-nucleon interactions.

b.2.5. Yrast Excitations in $N = 81$ Nuclei ^{132}Sb and ^{133}Te from ^{248}Cm Fission Studies
 (I. Ahmad, D. Seweryniak, I. Wiedenhöver, M. P. Carpenter, R. V. F. Janssens, T. L. Khoo, T. Lauritsen, C. J. Lister, P. Reiter, P. Bhattacharyya,* P. J. Daly,* C. T. Zhang,* Z. W. Grabowski,* S. K. Saha,* B. Fornal,† R. Broda,† W. Urban,‡ and J. Blomqvist§)

Structures of $N = 81$ isotones ^{132}Sb and ^{133}Te were studied by measuring coincidence gamma rays in the deexcitation of ^{248}Cm fission fragments. The multifold coincidence gamma rays were measured with the Gammasphere and a 5 mg ^{248}Cm source. Previously unknown yrast cascades in ^{132}Sb and ^{133}Te were identified in cross coincidence with known gamma rays from the complementary Rh and Ru fission fragments.

The ^{132}Sb levels are explained as proton-neutron hole states as well as core excited states of $2p - 2h$ character. The level scheme of ^{133}Te , shown in Fig. I-21, was interpreted mainly on the basis of shell model calculations using empirical proton-proton interaction energies from ^{134}Te together with estimated proton-neutron hole interactions. The results of this investigation were published.¹

*Purdue University, †IFJ Krakow, Poland, ‡Warsaw University, Poland, §Royal Institute of Technology, Stockholm, Sweden

¹P. Bhattacharyya et al., Phys. Rev. C **64**, 054312 (2001).

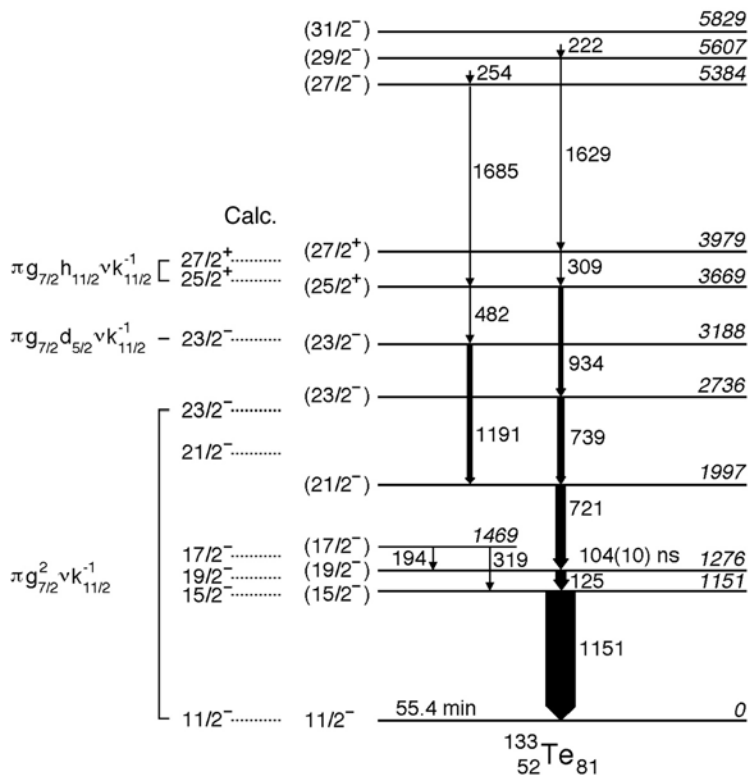

Fig. I-21. Level scheme of ^{133}Te showing the yrast gamma-ray cascade observed in the fission of ^{248}Cm . The dashed levels indicate calculated energies for $\pi^2 \nu^j$ states.

b.2.6. Excitations of Two- and Three-Valence Proton Nuclei ^{134}Te and ^{135}I

(I. Ahmad, D. Seweryniak, I. Wiedenhöver, M. P. Carpenter, R. V. F. Janssens, T. L. Khoo, T. Lauritsen, C. J. Lister, P. Reiter, S. K. Saha,* C. Constantinescu,* P. J. Daly,* P. Bhattacharyya,* C. T. Zhang,* Z. W. Grabowski,* B. Fornal,† and R. Broda†)

Prompt multifold coincidence gamma ray spectra were measured using a ^{248}Cm source and the Gammasphere when it was at Argonne. Analysis of the data set has provided structures of many neutron-rich nuclei. We have focused our analysis on structure of nuclei around the doubly magic ^{132}Sn . By studying nuclei with few

valence protons and/or valence neutrons we have been able to investigate neutron-proton interaction. The new analysis of the ^{248}Cm data has revealed new levels in ^{134}Te and ^{135}I . These levels are well explained by shell model calculations and thus provide further test of the interaction. The results of this study were published.¹

*Purdue University, †INP Krakow, Poland

¹S. K. Saha et al., Phys. Rev. C **65**, 017302 (2002).

b.2.7. First Measurement of Yrast Excitations in ^{137}I and the Missing 12^+ Isomer in ^{136}Te
 (I. Ahmad, L. R. Morss, ¶ A. Korgul,* W. Urban,* T. Rzaca-Urban,* M. Gorska, †
 J. L. Durell, ‡ M. J. Leddy, ‡ M. A. Jones, ‡ W. R. Phillips, ‡ A. G. Smith, ‡ B. J. Varley, ‡
 M. Bentaleb, § E. Lubkiewicz, § and N. Schulz, §)

The excited states in ^{137}I , populated in the spontaneous fission of ^{248}Cm , have been studied by means of prompt coincident gamma-ray spectroscopy using Eurogam2 germanium array. Medium-spin yrast excitations in ^{137}I were observed for the first time. The experimental level scheme was compared with calculations made

with shell model using Kuo-Herling interaction. The calculated values were found to differ significantly from the measured values. The two level schemes are displayed in Fig. I-22. The results of this study were published.¹

*Warsaw University, Poland, †Catholic University, Leuven, Belgium, ‡University of Manchester, United Kingdom, §IREs, Strasbourg, France, ¶Chemistry Division, ANL
¹A. Korgul et al., Eur. Phys. J. A **12**, 129 (2001).

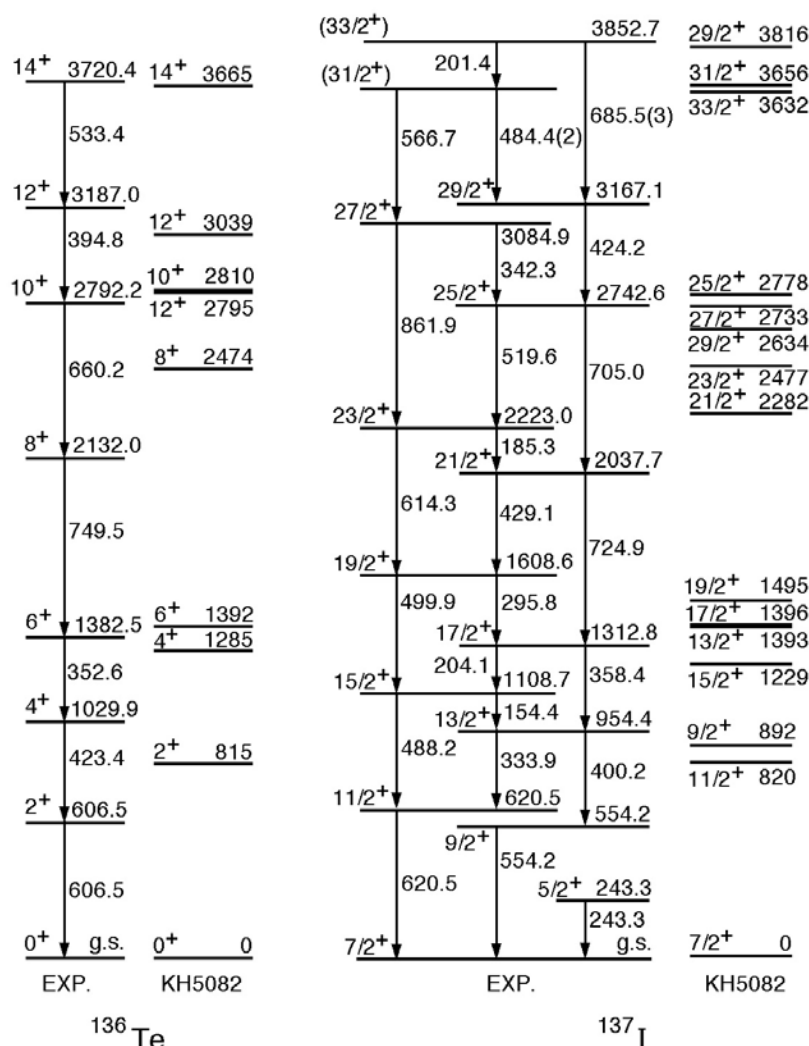

Fig. I-22. Partial level schemes of ^{137}I and ^{136}Te obtained in the present work. For both nuclei, shell model predictions are also included.

b.2.8. First Observation of Excited States in ^{139}I (I. Ahmad, L. R. Morss,§ W. Urban,*
T. Rzaca-Urban,* A. Korgul,* J. L. Durell,† M. J. Leddy,† M. A. Jones,†
W. R. Phillips,† A. G. Smith,† B. J. Varley,† and N. Schulz‡)

The structure of the nucleus ^{139}I has been determined for the first time. Levels in ^{139}I were studied by measuring coincidence gamma rays produced in the deexcitation of ^{248}Cm fission fragments. The experiment was performed with a 5 mg ^{248}Cm source and Eurogam2 gamma array. The assignment of the gamma rays to ^{139}I was based on the correlation between masses of iodine isotopes and the mean masses of complementary Tc isotopes. Multipolarities of transitions in ^{139}I were deduced from angular correlations and directional-polarization measurements.

Level scheme of ^{139}I deduced from the present work is shown in Fig. I-23. The level spins and parities are determined relative to $7/2^+$ ground state, which was deduced from the systematic trend of lowest yrast excitations in the odd-Z, $N = 86$ isotones. The excited states shown in Fig. I-23 indicate patterns characteristic of spherical vibrator. The level scheme of ^{139}I is similar to that of ^{137}I but it shows more collectivity as indicated by the lower transition energies. The results of this study were published.¹

*Warsaw University, Poland, †University of Manchester, United Kingdom, ‡IREs, Strasbourg, France, §Chemistry Division, ANL

¹W. Urban et al., Phys. Rev. **C65**, 024307 (2002).

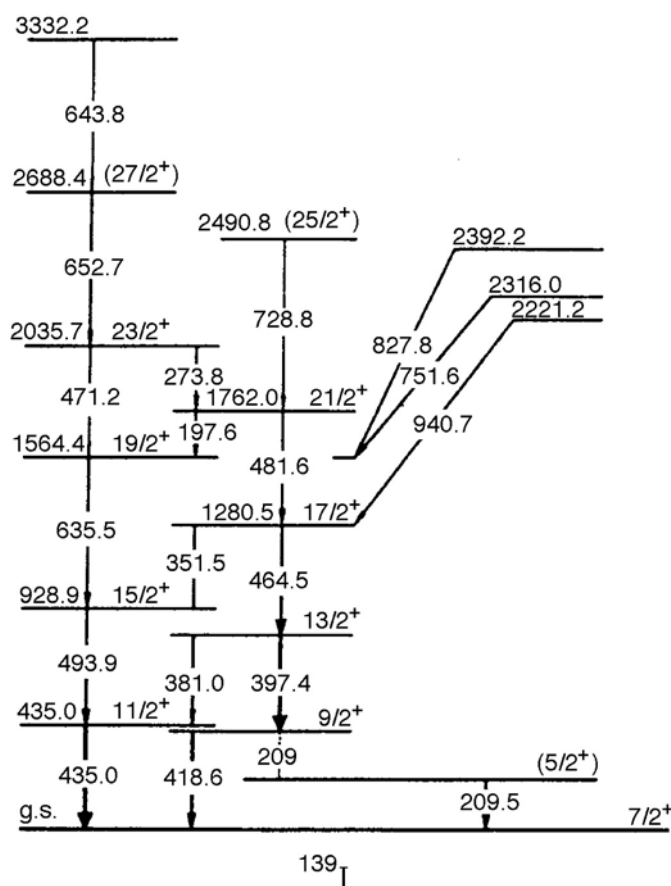

Fig. I-23. Partial level scheme of ^{139}I deduced from the analysis of ^{248}Cm fission data.

b.2.9. Observation of Rotation Bands in Neutron-Rich ^{107}Ru Nucleus (I. Ahmad, J. P. Greene, R. V. F. Janssens, S. J. Zhu,*†‡ J. H. Hamilton,† A. V. Ramayya,† J. K. Hwang,† C. Y. Gan,* X. Q. Zhang,† C. J. Beyer,† J. Kormicki,† M. Sakhee,* L. M. Yang,* L. Y. Zhu,* R. Q. Xu,* Z. Zhang,* Z. Jiang,* W. C. Ma,§ E. F. Jones,† P. M. Gore,† J. D. Cole,¶ M. W. Drigert,¶ I. Y. Lee,|| J. O. Rasmussen,|| T. N. Ginter,|| Y. X. Luo,†|| S. C. Wu,|| C. Folden,|| P. Fallon,|| P. Zielinski,|| K. E. Gregorich,|| A. O. Macchiavelli,|| S. J. Asztalos,‡ G. M. Ter-Akopian,** Yu. Ts. Ogenassian,** and M. A. Stoyer††)

Levels in the neutron-rich, odd-mass ^{107}Ru nucleus have been investigated with Gammasphere by measuring high-fold, prompt coincidence events following spontaneous fission of ^{252}Cf . A ~ 60 microCurie ^{252}Cf source sandwiched between two 15 mg/cm^2 iron foils was used for these measurements which were carried out with Gammasphere at Berkeley. On the basis of the results obtained in the present study, the ground state band of ^{107}Ru has been extended up to

27/2. The structure associated with $h_{11/2}$ excitation has been confirmed and extended to higher spin. The $h_{11/2}$ band head has been established at 301.8 keV. These results clarify the differences between our earlier work and results from other experiments published recently. A new collective band based on a $9/2^-$ level has been identified for the first time. The results of this investigation were published.¹

*Tsinghua University, Beijing, China, †Vanderbilt University, ‡Oak Ridge National Laboratory, §Mississippi State University, ¶INEEL, Idaho Falls, ||Lawrence Berkeley National Laboratory, **JINR Dubna, Russia, ††Lawrence Livermore National Laboratory

¹S. J. Zhu *et al.*, Phys. Rev. C **65**, 014307 (2001).

b.2.10. Mass Measurements of Short-Lived Neutron-Rich Isotopes at the Canadian Penning Trap Mass Spectrometer (G. Savard, J. P. Greene, A. Heinz, D. Seweryniak, J. A. Clark,* R. C. Barber,* C. Boudreau,† F. Buchinger,† J. E. Crawford,† S. Gulick,† J. C. Hardy,‡ J. K. P. Lee,† R. B. Moore,† K. S. Sharma,* G. Sprouse,§ J. Vaz,* and J. C. Wang*)

The Canadian Penning Trap (CPT) mass spectrometer is designed to make precise mass measurements on short-lived isotopes. Up until now, work had concentrated on short-lived neutron-deficient isotopes produced on-line at the ATLAS facility and stable isotopes. The recent overall efficiency gain in the injection system of the CPT now allows us to look at much more weakly produced isotopes. A region of great physical interest is that of the neutron rich-isotopes whose masses are critical to our understanding of the astrophysical r-process. These isotopes can be produced on-line but also, for a large fraction of them, they can be obtained more simply in small quantity from a fission source.

With the increased efficiency of the system, we have been able to perform a preliminary study of 6 heavy neutron-rich isotopes produced by the $6 \mu\text{Ci}$ ^{252}Cf source that we have previously been using for efficiency calibration of the gas cell/gas cooler system.

^{252}Cf decays with 97% probability by alpha emission and only with 3% probability by fission. The yield of any specific isotope is further diluted by the fission fragment distribution shown in Fig. I-24. The fission distribution peaks at about 0.03 per fission, or 0.001 per ^{252}Cf decay. This yields for the source available a total production of about 200 ions per second emitted into 4π steradians. The fission source is installed outside the gas cell and about 8% of the heavy fission fragments are emitted in a solid angle such that they can go through the entrance HAVAR window and be stopped in the gas cell. About 45% of those are extracted as ions from the gas cell, with about 2/3 of them concentrated in one charge state. They are then cooled in the gas cooler (with about 80% efficiency) before being transferred every 50 ms to the CPT accumulation linear RFQ trap and then the precision Penning trap where the actual mass measurement takes place. These transfer processes have efficiencies of about 80% and

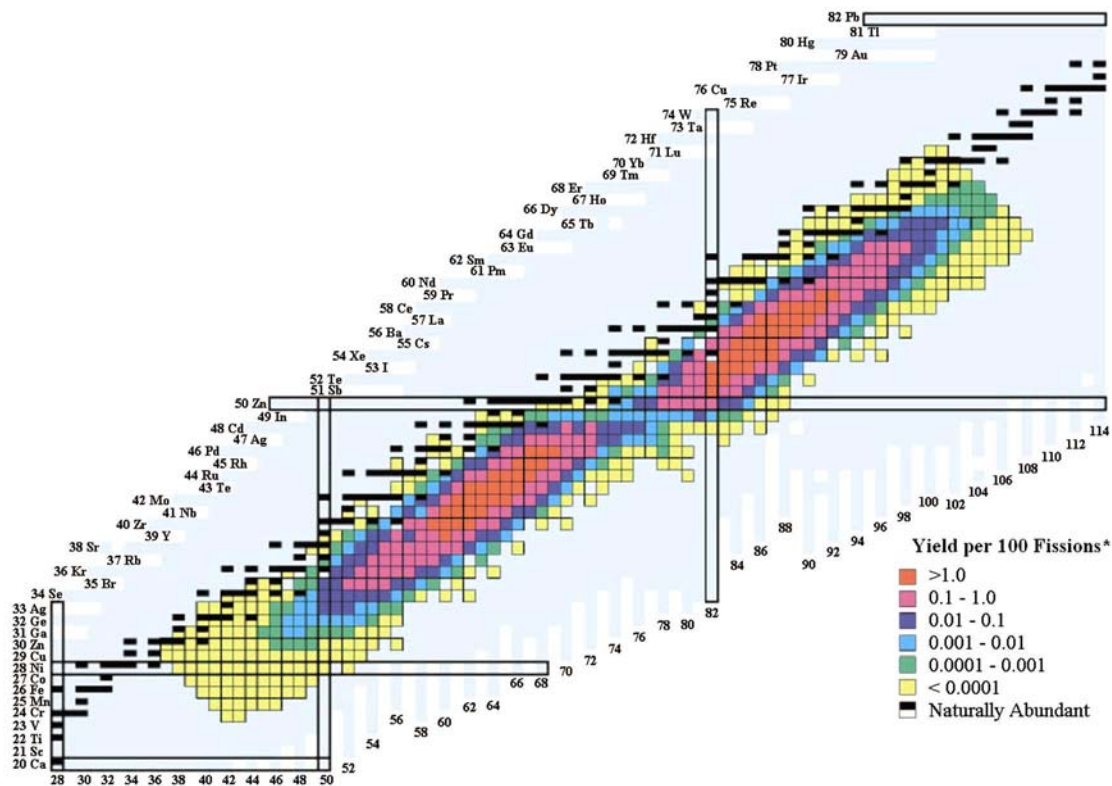

Fig. I-24. Fission yield distribution for ^{252}Cf .

60%. The cyclotron resonance used to determine the mass of the isotope of interest is measured with a time-of-flight technique where the ions are detected by a microchannel plate detector with a 40% efficiency. About 0.8 ion per second is detected at this final detector for an efficiency from the stopping in the gas cell to the detection of ions from one specific charge state after the precision Penning trap of about 5%. The total efficiency from production to detection, which also includes the low probability of stopping of the fission fragments inside the cell because of the emission in 4π solid angle, is about 0.4%.

Using this approach, we have measured with a resolution of about 1 part in 700000 and an accuracy of about 10^{-7} the mass of 6 neutron rich isotopes: ^{145}Ba (see Fig. I-25), ^{145}La , ^{147}La , ^{147}Ce , ^{149}Ce and ^{149}Pr . These isotopes have half-lives down to about 4 seconds and in all cases the new mass values will be a significant improvement over previously know masses. These measurements will be extended to more weakly produced nuclides in the coming year.

*University of Manitoba, Winnipeg, Manitoba†, McGill University, Montreal, Quebec, ‡Texas A&M University, §Argonne National Laboratory and State University of New York

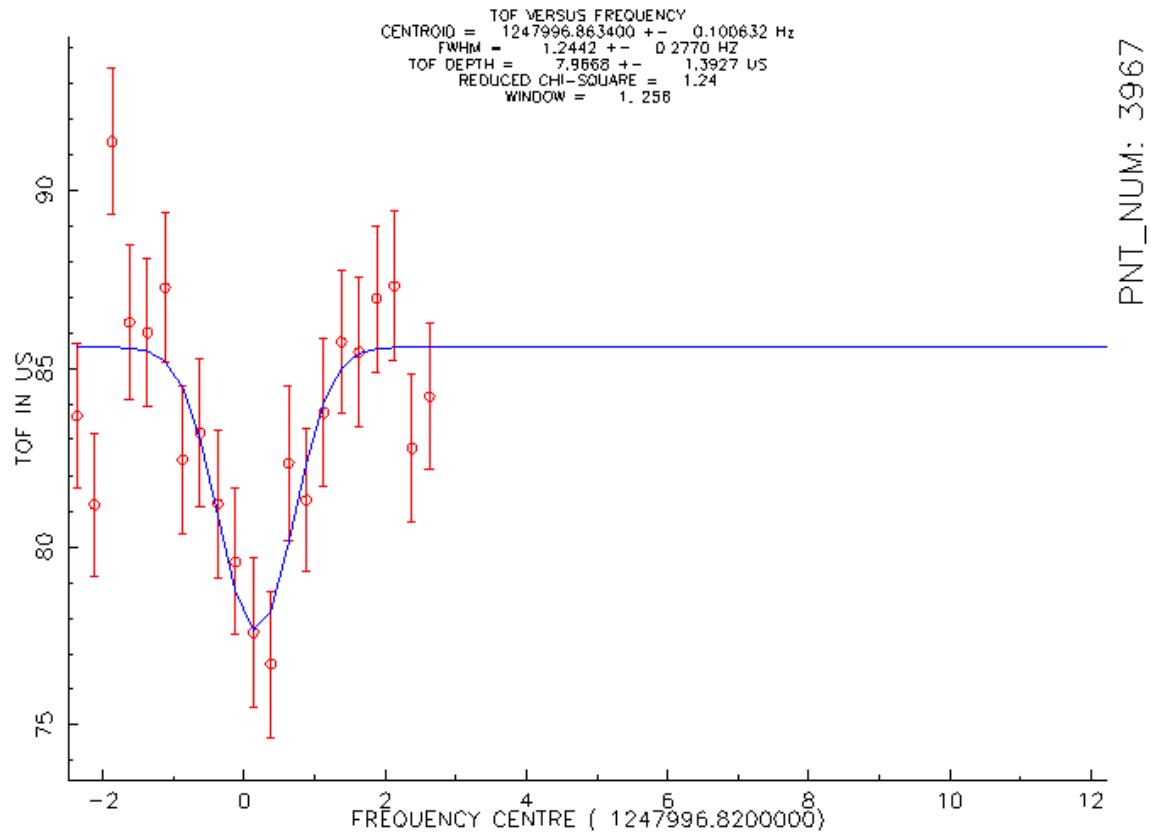

Fig. I-25. Typical resonance obtained in an afternoon of data taking for ^{145}Ba ($t_{1/2} = 4.0\text{s}$).