

Progress Toward an EDM Measurement in ^{225}Ra

R. J. Holt¹, I. Ahmad¹, K. Bailey¹, B. Graner^{1,2}, J. P. Greene¹, W. Korsch³
Z.-T. Lu^{1,2}, P. Mueller¹, T. P. O'Connor¹, I. A. Sulai^{1,2}, W. L. Trimble¹

¹*Physics Division, Argonne National Laboratory, IL, USA*

²*Department of Physics and Enrico Fermi Institute, The University of Chicago, IL, USA*

³*Department of Physics and Astronomy, University of Kentucky, KY, USA*

Abstract

Permanent electric dipole moments (EDMs) in atoms or molecules are a signature of time-reversal and parity violation and represent an important window onto physics beyond the Standard Model. We are developing a next generation EDM search based on laser-cooled and trapped ^{225}Ra atoms. Due to octupole deformation of the nucleus, ^{225}Ra is predicted to be two to three orders of magnitude more sensitive to T-violating interactions than ^{199}Hg , which currently sets the most stringent limits in the nuclear sector. We will discuss progress toward realizing a first EDM measurement for ^{225}Ra .

Key words:

PACS: 32.30.Jc, 24.80.+y

1. Introduction

The quest for nonzero permanent electric dipole moments (EDMs) represents an extremely interesting opportunity to search for new physics beyond the Standard Model. The three general classes of searches for non-zero EDMs are for the neutron, nuclei (diamagnetic atoms) and the electron (paramagnetic atoms and molecules). In order to fully understand the origin of a non-zero EDM, it is necessary to measure the EDM in all three systems. Interest in low energy tests of the Standard Model have burgeoned during the past decade in large part due to the same motivation that has driven interest in developing the Large Hadron Collider (LHC) at CERN. Recent reviews of the physics and connections are given in ref. [1–5]. If evidence for new physics is found at the LHC, then low energy tests will be essential to help determine the parameters of the new Standard Model. If no new physics is discovered at the LHC, then low energy experiments could well be first to discover evidence for the new Standard Model. Thus, low energy Standard Model tests have risen steadily in importance in nuclear physics in recent years.

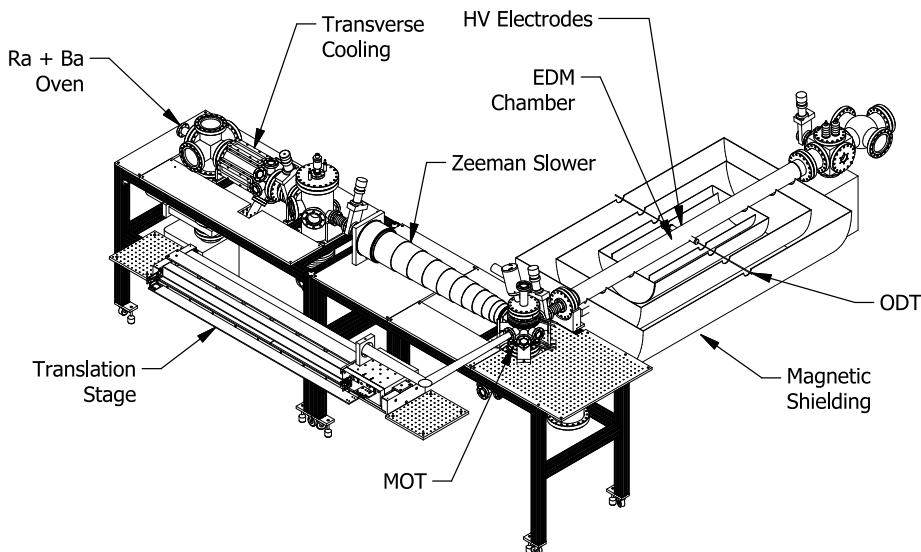

Fig. 1. Schematic diagram of the EDM setup

In this work, we describe the progress in developing an experiment to search for a nonzero EDM in ^{225}Ra . The most sensitive measurement to date for diamagnetic atoms was recently performed for ^{199}Hg . Here the EDM was found[6] to be less than 3×10^{-29} e-cm at the 90% confidence level. Generally speaking, the measurements in diamagnetic atoms lose sensitivity to the nuclear EDM because of Schiff screening, typically by three orders of magnitude. It has been shown[7] that in atoms of octupole deformed nuclei, the EDM effect can become enhanced by two to three orders of magnitude, thereby mostly compensating for the Schiff screening problem. In the present work, we have selected ^{225}Ra because it has a relatively large enhancement[7–9], a reasonably long half-life ($T_{1/2} = 14.9$ days) so that a table-top, non-accelerator based experiment could be performed, and spin $\frac{1}{2}$ so that magnetic quadrupole effects are eliminated.

2. The Experiment

In this work we will exploit both the enhancement due to octupole deformation of ^{225}Ra and the beneficial properties of optically trapped atoms. Optically trapped atoms exhibit a small velocity (~ 1 mm/s), form a compact cloud (~ 1 mm), and have a long coherence time for polarized atoms (~ 100 s). The EDM measurement will be performed in an optical dipole trap[10] (ODT) as indicated in Fig. 1. Here the ^{225}Ra atoms emerging from a highly collimated oven are first transversely cooled and then longitudinally slowed in the Zeeman slower before being trapped in a magneto-optical trap (MOT). The cooling scheme used for the transverse cooler, the Zeeman slower and the MOT is based on the cycling transition at 714 nm as indicated in Fig. 2. After approximately 2×10^4 of these transitions, the atoms leak to a “dark” state, say the 3D_1 state. A 1428 nm “repump” laser is used to excite atoms from the 3D_1 “dark” state to the ground state *via* the 1P_1

Table 1

Measured transition energies (Fig 2) in ^{225}Ra and ^{226}Ra .

Transition	$^1S_0 - ^3P_1$	$^1S_0 - ^3P_1$	$^1S_0 - ^1P_1$	$^3D_1 - ^1P_1$
Atomic species	^{225}Ra	^{226}Ra	^{226}Ra	^{226}Ra
(cm^{-1})	13999.269(1)	13999.357(1)	20715.598(6)	6999.84(2)

state preserving the cycling transition for up to $\sim 10^7$ cycles. It was discovered[11] that this process is assisted by blackbody radiation which can induce transitions between the 3P_1 and 3D_1 levels. Thus far, we have trapped up to 15000 radium atoms in the MOT with a trap lifetime of 5 s. This represents an improvement in the number of trapped radium atoms by a factor of 20 compared to that of our previous work ref [11]. The improvement is largely due to a more efficient transverse cooling scheme and an improved vacuum in the MOT region. The plan is to transfer the atoms in the MOT to an optical dipole trap. The optical dipole trap makes use of a $1.5 \mu\text{m}$, 10-W fiber laser. The focus of the fiber laser will be moved, using an air-bearing translation stage for the optics, to a 2-mm gap between high voltage electrodes where the EDM will be measured. A necessary step in optically trapping radium atoms was determining a number of physical properties of $^{225,226}\text{Ra}$. First the transition energies of the cycling transitions were measured for ^{225}Ra and ^{226}Ra and summarized in Table 1. In addition, the lifetime of the $^3P_1 \rightarrow ^1S_0$ transition was determined to be 422(20) ns. The lifetime of this state established the magnitude of the cooling force for the cycling transition.

The magnetic field conditions necessary for an EDM measurement have been established. Three concentric mu-metal shields were designed, constructed and tested. An overall shielding factor of approximately 10^5 was achieved. A $\cos \theta$ coil was designed, constructed and tested. The field gradient in the EDM region of 10^{-5} G/cm was attained. Two optical Rb magnetometers based on a method described in ref [12] were constructed and tested *in situ* in the shields. A resolution, limited by noise, of $\sim 10^{-6}$ was achieved. The $\cos \theta$ coil was powered by an ultra-low noise (25 ppb) current source. The high electric field (100 kV/cm) was produced by a pair of electro-polished Cu electrodes. This high field was attained with a leakage current of less than 50 pA which is sufficient for the EDM experiment.

The error limit, δd on an EDM signal expected from the experiment can be estimated from

$$\delta d = \frac{h}{2E\sqrt{\tau N \epsilon T}}$$

where h is the Planck constant, E is the external electric field, τ is the coherence time of

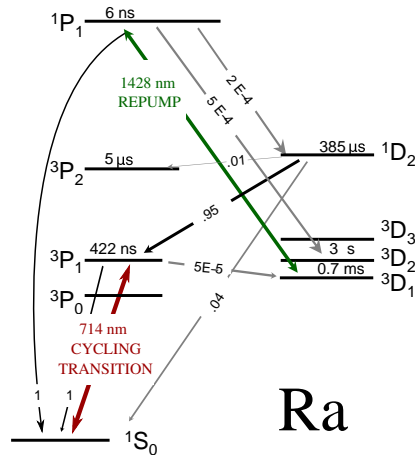

Fig. 2. Level diagram for low-lying excited states of radium. The 714-nm transition is used as the laser cooling cycling transition in this work. The 1428-nm transition is used to return atoms to the ground state *via* the $^1P_1 - ^1S_0$ transition from the long-lived 3D_1 state. The lifetimes for the 1D_2 and 3P_1 states are experimentally determined.

the stored atoms, T is the measurement time, and ϵ is the efficiency of the measurement. Using Eq. 1 the projections for the near term field and the long term phases of the experiment are 10^{-26} e-cm for 10^4 atoms, 100 kV/cm field, a coherence time of 100 s and 10 days of measurement at 50% efficiency. In a second phase of the experiment, we would increase the number of atoms to 10^6 and the measurement time to 100 days to achieve a limit of 3×10^{-28} e-cm. The large gain in sensitivity for this experiment is then realized when the enhancement of a factor from the octupole deformation of ^{225}Ra (100 to 1000) is taken into account.

Approximately 10^6 trapped atoms will be necessary for a more sensitive phase of the experiment. At present a scheme that makes use of the $^1S_0 - ^1P_1$ transition is being evaluated as a means to increase the radium atoms in the trap by a factor of 100. Although additional repump lasers would be necessary, this scheme has already been demonstrated[13] at KVI for trapping barium atoms.

3. Summary

In summary, we have provided new data necessary for the optical trapping of Ra atoms and have applied these data to the trapping of ^{225}Ra and ^{226}Ra atoms. We have improved the record for trapping radium atoms by approximately a factor of 20 from our previous work. Effort is underway to load the radium atoms in the MOT into the ODT. We have established the vacuum, magnetic and electric field conditions necessary to begin an EDM experiment.

Acknowledgments

We thank C. Ciofi for the loan of the ultra-low noise current source. Also we thank H. Gould for useful discussions. This work is supported by the U.S. Department of Energy, Office of Nuclear Physics, under contract no. DE-AC02-06CH11357.

References

- [1] M. Raidal, et al., Eur. Phys. J. C57 (2008) 13–182.
- [2] J. Erler, M. J. Ramsey-Musolf, Prog. Part. Nucl. Phys. 54 (2005) 351–442.
- [3] M. J. Ramsey-Musolf, S. Su, Phys. Rept. 456 (2008) 1–88.
- [4] K. A. Olive, M. Pospelov, A. Ritz, Y. Santoso, Phys. Rev. D72 (2005) 075001.
- [5] M. Pospelov, A. Ritz, Y. Santoso, Phys. Rev. D74 (2006) 075006.
- [6] W. C. Griffith, et al., Phys. Rev. Lett. 102 (2009) 101601.
- [7] V. Spevak, N. Auerbach, V. V. Flambaum, Phys. Rev. C56 (1997) 1357–1369.
- [8] J. Engel, J. L. Friar, A. C. Hayes, Phys. Rev. C61 (2000) 035502.
- [9] J. Engel, M. Bender, J. Dobaczewski, J. H. De Jesus, P. Olbratowski, Phys. Rev. C68 (2003) 025501.
- [10] M. V. Romalis, E. N. Fortson, Phys. Rev. A59 (1999) 4547–4558.
- [11] J. R. Guest, et al., Phys. Rev. Lett. 98 (2007) 093001.
- [12] J. Higbie, E. Corsini, D. Budker, Rev. Sci. Instrum. 77 (2006) 113106.
- [13] H. Wilschut, talk presented at this symposium.